



INNOVATION. **PRECISION.** EXCELLENCE.



Pump Specifications

Operating Temperature

10 - 40°C (50 - 104°F)

Viscosity Range

1 - 500,000+ cps

Max Inlet Fluid Pressure

85 psi

Max Discharge Pressure

285 psi

Wetted Components

Stainless Steel/FFKM
Carbide/EPDM

Dimensions, Flow Rate, and Fluid Inlet will vary based on pump size. See table on page 2.



PDP Series

Progressive Cavity Dual Pump

The PDP Series of progressive cavity pumps bring superior volumetric accuracy to your most demanding two-component dispensing applications. Progressive cavity pumps feature a machined rotor that couples with a rubberized seal to assure drip-free operation with a wide range of viscous chemistries. Each servo-controlled rotor displaces a fixed volume of material per revolution. This true positive displacement process assures consistent volume regardless of slight material variations.

The PDP Series features independently controlled pumps for both resin and hardener allowing users the ability to customize their desired mix ratio. Five different rotor sizes span a wide range of flow rates. An optional carbide rotor is available for extended life when processing filled or abrasive chemistries.

The PDP Series has many additional integrated features including:

- Programmable flow rate and mix ratio (1:1 to 10:1)
- High precision dosing within +/-1%
- Continuous dispensing process for efficient operation and no refilling
- Self sealing operation prevents dripping
- Optional carbide rotor for abrasive chemistries

For more information, please contact PVA at info@pva.net or contact your local representative.

REV D 12/31/21

Headquarters
6 Corporate Drive | Halfmoon, NY 12065
tel +1 518 371 2684 | fx +1 518 371 2688
www.pva.net | info@pva.net

PDP Mounting Dimensions

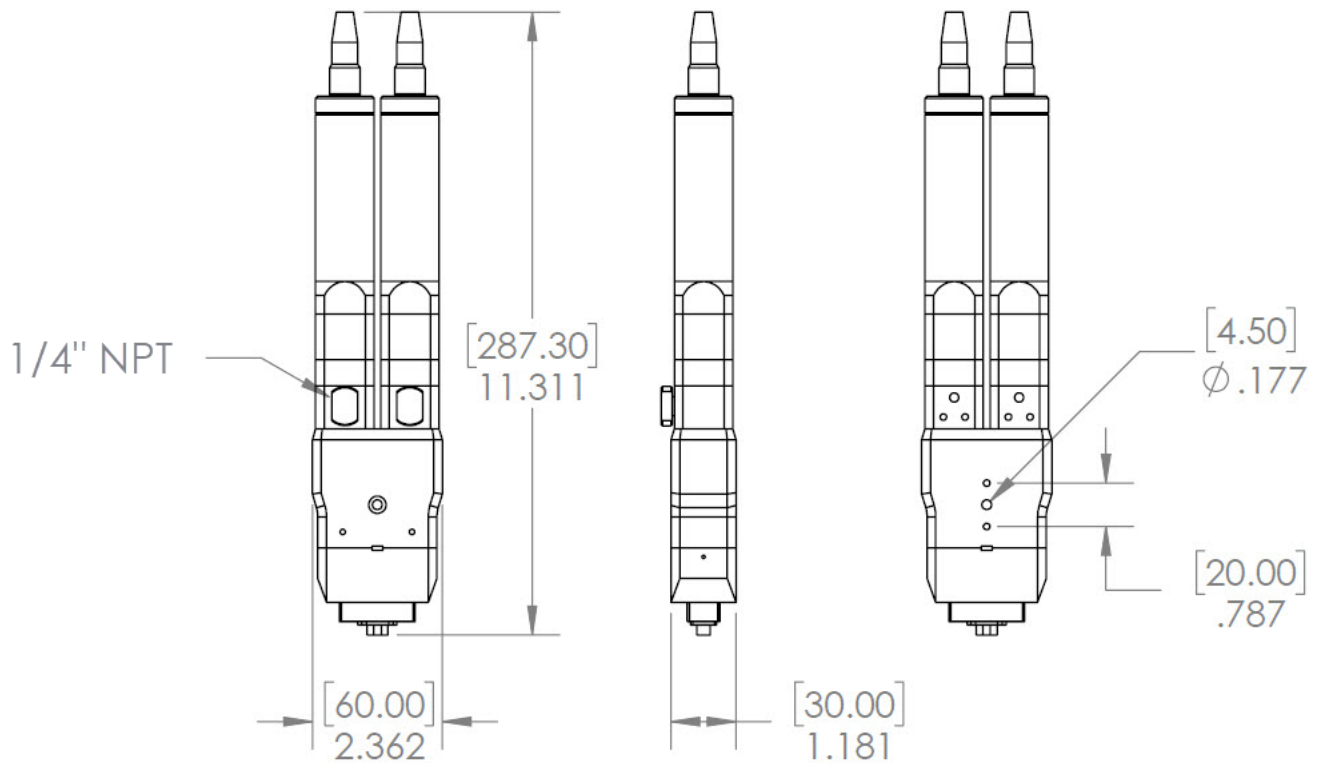

*Dimensions may vary based on pump size

Model Specifications

Model Number	Flow Rate	Dimensions (mm)	Fluid Inlet
PDP015	0.03 - 3.6 ml/min	60 x 30 x 260	1/4" NPT
PDP015-C	0.03 - 0.3 ml/min	60 x 30 x 260	1/4" NPT
PDP050	0.1 - 12 ml/min	60 x 30 x 260	1/4" NPT
PDP050-C	0.1 - 1 ml/min	60 x 30 x 260	1/4" NPT
PDP150	0.3 - 36 ml/min	67 x 35 x 310	1/4" NPT
PDP150-C	0.3 - 3 ml/min	67 x 35 x 310	1/4" NPT
PDP500	1 - 120 ml/min	67 x 35 x 310	1/4" NPT
PDP500-C	1 - 10 ml/min	67 x 35 x 310	1/4" NPT
PDP1000	2 - 240 ml/min	67 x 35 x 340	1/4" NPT
PDP1000-C	2 - 20 ml/min	67 x 35 x 340	1/4" NPT

*Based on 1:1 Ratio. Material Dependent